

evobike street 250

User Manual

Folding Electric Scooter

Thank you for having chosen evobike street 250 electric scooter (hereinafter referred to as electric scooter). It is a sports and recreational vehicle with style.



WARNING

ON motorway is prohibited!

About the Instruction Manual:

This manual contains important safety information and advises on the proper use of the vehicle. Read it entirely before taking your first ride on your new electric scooter.

The package contains: Assembled electric scooter, charging adapter, instruction manual, and accessories (screws, Hexagon socket wrench, extended nozzle adapter).

Contents

1. Function Diagram.....	1
2. Controls and Instrument.....	2
3. Assembly and Set-up.....	2
4. Charger connection.....	3
5. How to Ride.....	3
6. Warning! Dangerous Behaviors.....	4
7. Safety Instructions.....	6
8. Folding and Carrying.....	7
9. Daily Care and Maintenance.....	8
10. Specifications.....	9
11. Accessories.....	9

1 Function Diagram

Product Overview

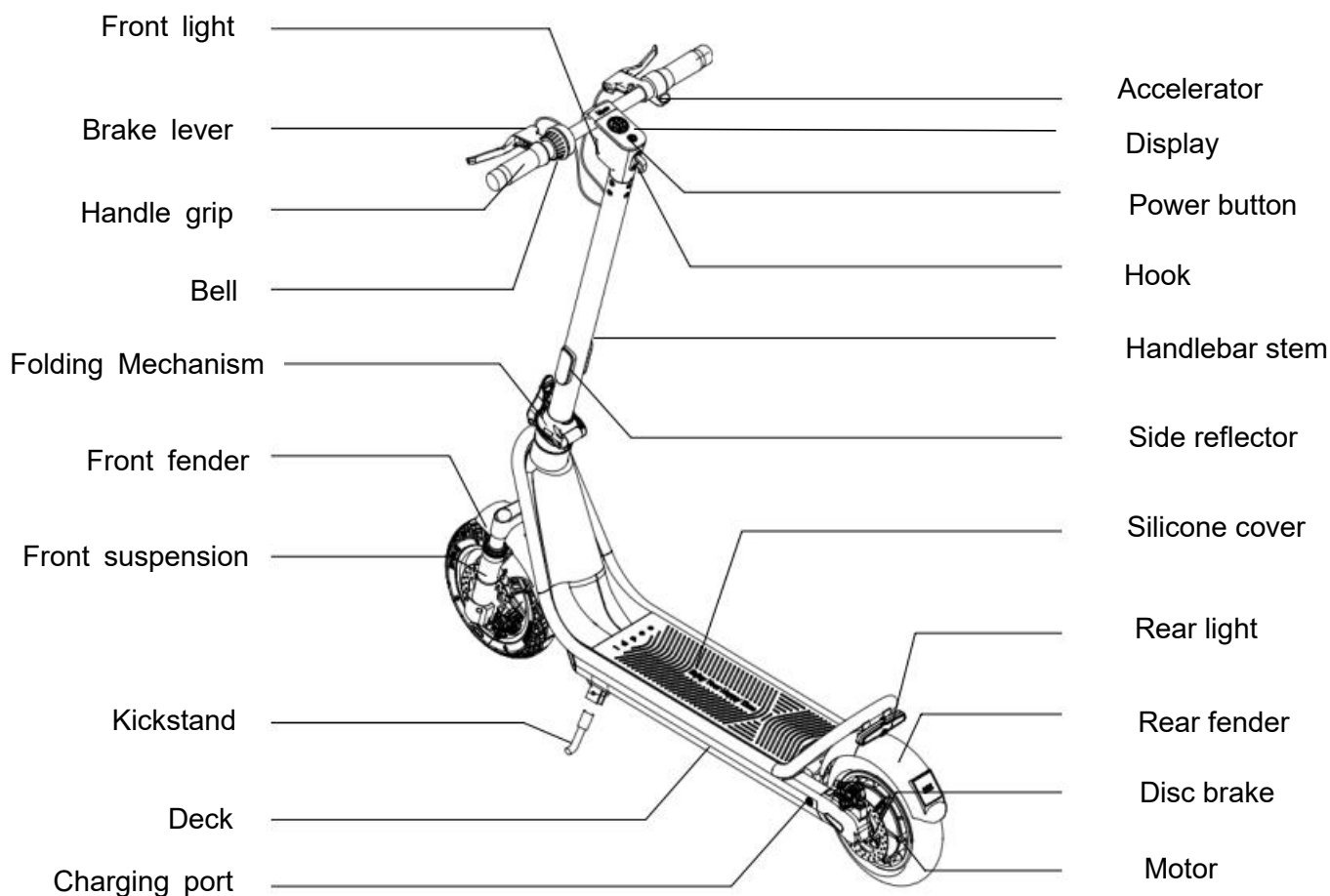

Control Panel Function Diagram

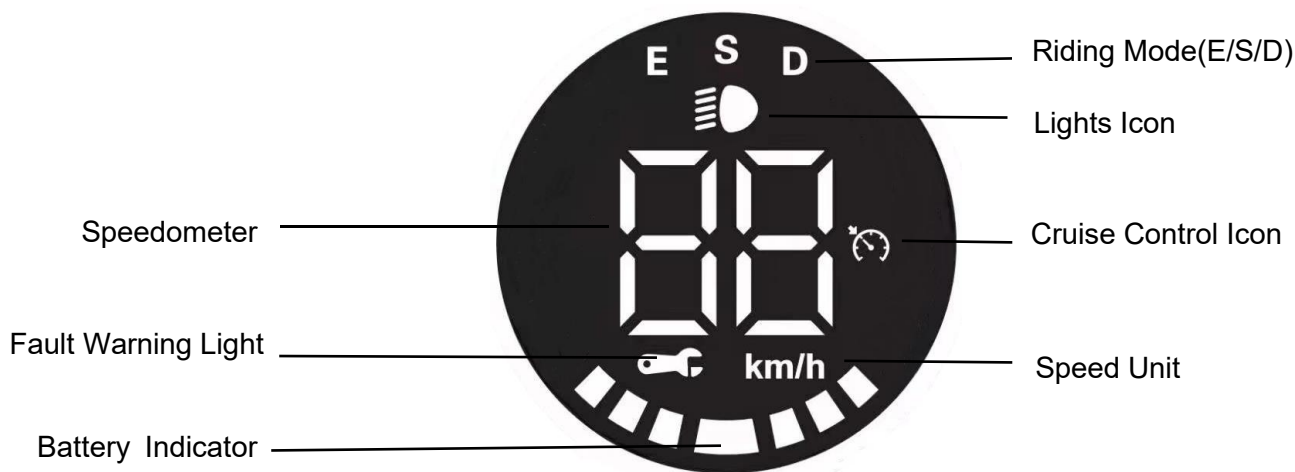

2 Controls and Instrument

- 2.1 Power Button: Long press on the power button for 3 seconds to turn on/off the electric scooter. When the electric scooter is power on, quick click the power button once to switch between three riding modes: Eco Mode, Standard Mode and Sport Mode, quick press the power button twice to turn on/off the lights.
- 2.2 Riding Mode Selection: There are three modes for riding mode selection, including "E" for eco mode, "D" for standard mode and "S" for sport mode. Quick click the power button to switch the mode. The Max speed of the 3 modes are: 6km/h for "E" mode, 15km/h for "D" mode and 20km/h for "S" mode.
- 2.3 Speedometer: Indicate the current speed of the electric scooter. It will indicate a fault code when a problem occurred to the electric Scooter.
- 2.4 Headlight: Quick click the power button twice to turn on/off the headlight.
- 2.5 Fault Warning Light: Warning sign of the electronic control system. The alarm symbol will light up when an electronic control system fault occurred.
- 2.6 Cruise control: it will automatically enter into cruise control mode If the throttle continues to work for 10 seconds at the same speed. There is a cruise control signal on display. At this time, any operation can exit the cruise control mode for example, press acceleration or brake lever.
- 2.7 Battery Indicator Lights: With the consumption of battery power, the charging warning lights will change from solid to off from up to down. When the arc battery indicator lights are fully displayed, the electricity is about 100%, the battery indicator lights will turn off with the power consumption. When the light at the bottom turns orange, it means that the battery is about to run out. Please recharge soon for future use. When the battery runs out, all the battery indicator lights go out, and the electric scooter will coast until it comes to a complete Stop.
- 2.8 Auto Power off: After 10mins without any operation, it will be powered off automatically.

3 Assembling your electric scooter

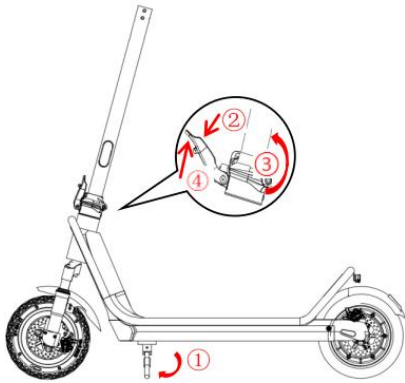

3.1 Put the kickstand down, press to unlock the folding mechanism, lift the handlebar stem, and then lock the folding mechanism.

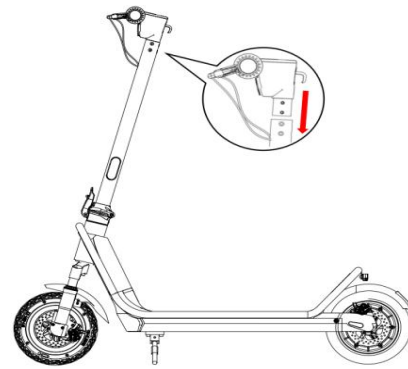

3.2 Firmly connect the wires inside the handle and the stem. Be aware of the correct orientation. Attach the handlebar to the handlebar stem.

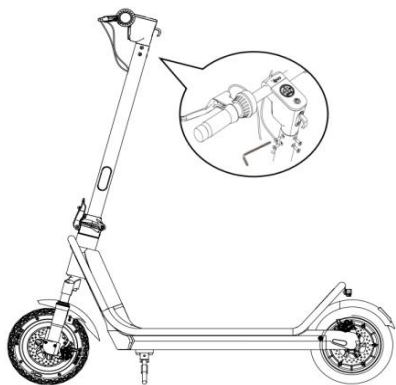

3.3 Take the hexagon wrench and M5 screws(6 pcs) out from The Accessories package, tighten two screws onto each of the Three sides of the Handlebar stem with the hexagon wrench.



3.4 After the assembly, turn on the power button to test whether the electric scooter works properly.

4 Charger Connection

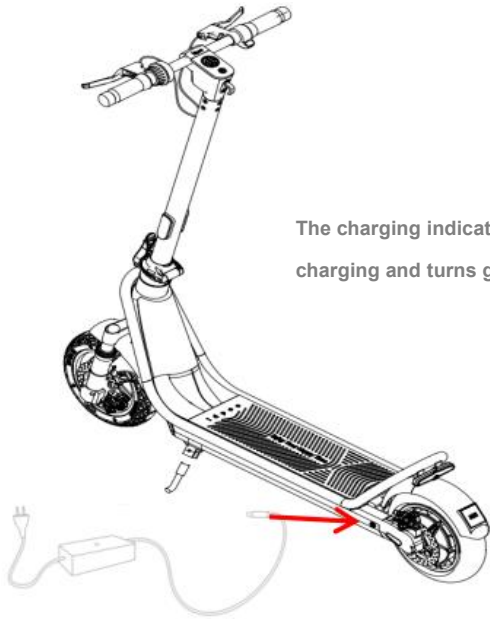

The charging indicator light is red on the process of charging and turns green when the battery is full.

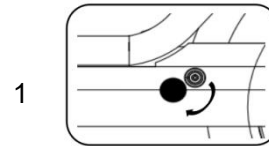

1

Lift the rubber cover

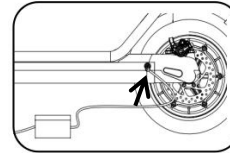

2

Plug the power adapter
into the charging port.

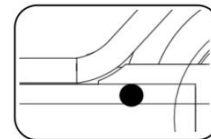

3

When charging is completed,
put back rubber cover tightly.

5 How to Ride

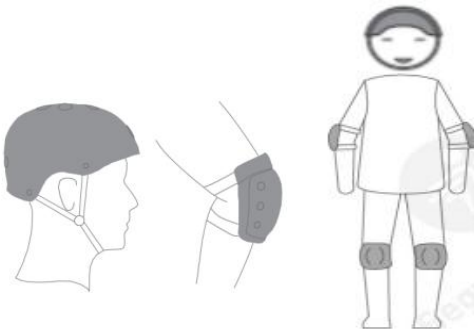

Wear helmets and protective gear all the time in case of falls and injuries when you learn to ride the scooter.



5.1 Turn on the power and check the battery indicator light.



5.2 Step on the deck with one foot, and the other foot kicks off slowly on the ground (exceeds the speed of 3km/h).

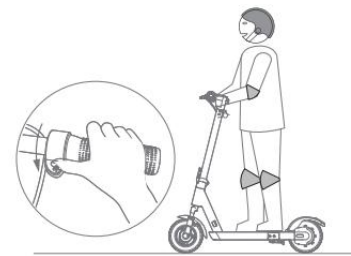

5.3 When the scooter starts to coasting, put both feet on the deck, and press the thumb shift accelerator when you can keep balance (the accelerator start to work once the coasting speed exceeds 3km/h).

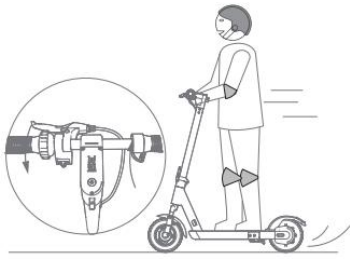

5.4 Release the thumb shift accelerator to slow down.
The energy recovery system (KERS) starts automatically to brake slowly; In a sudden brake, squeeze the brake handles on both sides of the handlebar.

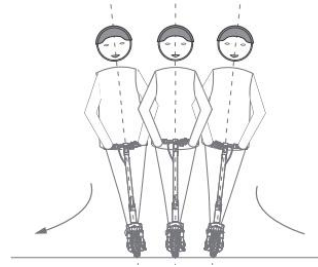

5.5 Tilt your body to the steering direction as you turn, and slowly turn the handlebar.

⚠ WARNING

When braking rapidly you risk serious injury due to loss of traction and falls.
Maintain a moderate speed and look out for potential hazards.

6 Warning! Dangerous Behaviors

⚠ WARNING

Failure to follow these instructions could lead to serious injury.



⚠ Do NOT ride the scooter in the rain



⚠ Do not cross rough roads at high speed. Keep your speed at 5-10km/h when you ride through speed bumps, elevator door sills, bumpy roads, or any other uneven surface. Slightly bend your knees will help when passing the above-mentioned road conditions.

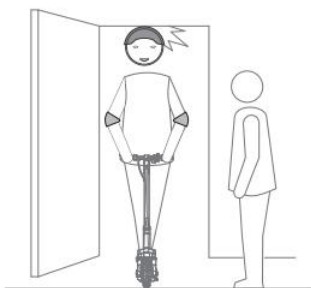

⚠ Watch out for the door frame, elevator door frame and other overhead obstacles.



⚠ Do not accelerate when you go down hill.

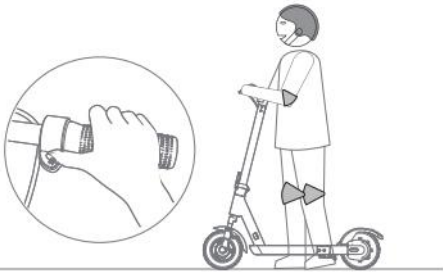

⚠ Do not press the accelerator when you're walking alongside the scooter.



⚠ Always steer clear of obstacles.



⚠ Do not hang bags or other heavy stuff on the handlebar.



⚠ Keep both feet on the deck when riding the scooter.

Do not try following dangerous action

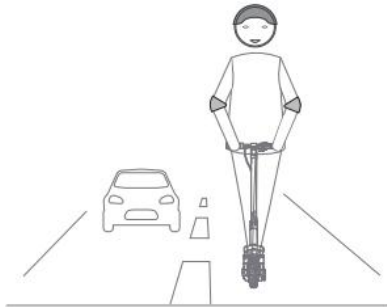

⊗ Do not ride in motorway or residential areas where vehicles and pedestrians are both allowed.

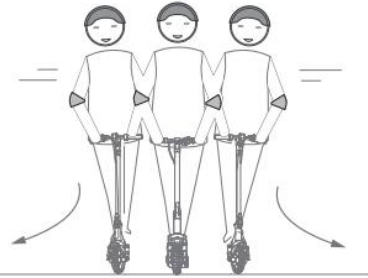

⊗ Do not turn the handlebar violently during high-speed riding.



⊗ Do not ride in a ponding with a depth of > 2cm.



⊗ Do not ride with anyone else, including children.

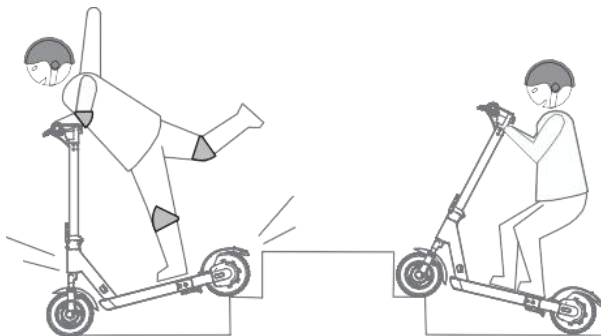

⊗ DO not ride up and down stairs or jump over obstacles.



⊗ Do not ride with both hands off the handlebars.

⚠ Always keep both hands on the handlebar or you risk Serious injury due to loss of balance and falls.



⊗ Do not step on the rear mudguard.

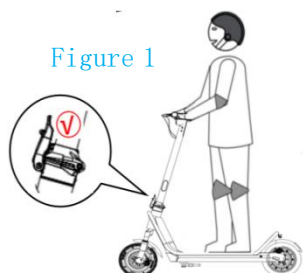

WARNING

When riding, the folding lock clasp must be in a locked state as shown in the figure(Figure 1) .



7 Safety Instructions

The electric scooter, as any riding device is subject to safety risks, you should read the instructions in the manual in detail and follow it strictly. Put your and others' safety at top priority during riding. Electric scooter is a convenient transportation tool, which can meet the needs of short distance transportation. Constant vigilance is essential during riding; thus, it is crucial to keep proper speed and distance from other people or vehicles. Stay vigilance and ride slowly when riding in dim and unfamiliar environments.

In some countries and regions, there are specific laws and regulations related to electric scooters riding in public area. Please follow the local laws and regulations when riding. For details, please consult relevant local authorities.

Safety Reminder:

- ★Wear helmets, gloves, elbow pads, and knee pads in case of falls and injuries before you ride the electric scooter.
- ★Check the vehicle: Check whether the power is sufficient, whether the vehicle has any problems like abnormal sound, loose parts. Check the steering and brakes before riding.
- ★Do not ride on rainy/ snowy days or wet roads, especially on snow, ice, and water roads; If unavoidable, ride slowly and keep 5 times the braking distance as usual.
- ★It is not recommended to ride on the uphill and downhill which the slope exceeds 15°.
- ★Children under 15 years old are not recommended to practice and ride.
- ★Do not ride in dim environments. If unavoidable, keep slow and vigilance.
- ★Reversing is dangerous. Avoid reversing unless you must avoid obstacles. In that case, please reverse a few steps at an extreme low speed.
- ★Please avoid sudden acceleration or deceleration, do not lean forward, or lean back too much, overspeed is strictly prohibited; When the remaining power is insufficient, please ride at a low constant speed and charge at your earliest convenience.
- ★In case of falling, please choose to protect your safety over the electric scooter
- ★In case of emergencies and unprepared conditions, do not put your hands in the pockets when riding.
- ★Do not put the electric scooter in the trunk of the car for a long time in hot weather.
- ★When riding, please take the initiative to learn and obey the local traffic laws and regulations, watch for the surroundings to avoid traffic collisions.
- ★Ride at a speed that is safe for both yourself and others around you, in a controlled manner.
- ★The faster you ride the electric scooter, the longer braking distance is required. Please keep at a certain speed and braking distance; Emergency braking on smooth road may lead to skidding, losing balance or even falling.
- ★The brake may get hot during riding. Do not touch it right away.
- ★Respect pedestrians' right of way, try not to startle them while riding, especially children. When you ride behind pedestrians, give them

a heads-up and slow down.

- ★ If the electric scooter is lent to others, it is your responsibility to keep the borrower safe. Coach him (her) before riding and remind him (her) to wear safety protective gear and precautions before riding.
- ★ When riding with other scooter riders, keep a proper safe distance and avoid obstacles. Do not ride side by side unless there is enough space for pedestrians.

Active safety protection measures:

Please read this instruction manual carefully, understand and endorse the contents.

- ★ Do not let others ride your scooter unless they have read this manual in detail.
- ★ Please take safety precautions when you ride. Please wear a certified and proper fitted helmet, with strap and covers the back head. Please also wear other protective equipment such as gloves, eye protectors, elbow protectors and knee protectors.
- ★ Do not ride when you feel unwell or cannot follow the instructions or warnings in this instrument manual. Do not ride under the influence of alcohol or drugs.
- ★ When the electric scooter is under the conditions of low power, continuous alarm, or speed limit, please get off and charge to ensure safety.
- ★ Do not lift the scooter from the tire, keep your fingers from getting pinched in the tire and the shell.
- ★ Please check the scooter every time before riding. If any looseness or damage occurred, do not ride it before the problem is solved. As with any mechanical component, a vehicle is subject to high stresses and wear. The various materials and components may with may react differently to wear or fatigue. If the expected service life for a component has been exceeded, it may break suddenly, therefore risking causing injuries to the user. Cracks and discoloration in the areas subject to high stresses indicate that the component has exceeded its service life and should be replaced.

WARNING!

Please closely follow the safety instructions in the instruction manual, Please accelerate slowly, sudden acceleration can easily cause the scooter to lose balance and lead to falls and injuries! This habit is very dangerous and is responsible for most accidental falls and offbalance injuries. During riding, you may encounter sudden danger, so you should ride carefully at any time.

When charging the electric scooter, please choose the original charging adapter and charge it in the designated safe, open, and ventilated place. It is forbidden to charge it in a humid and stagnant environment or a closed space containing inflammable and explosive items like the living room and bedroom.

8 Folding and Carrying

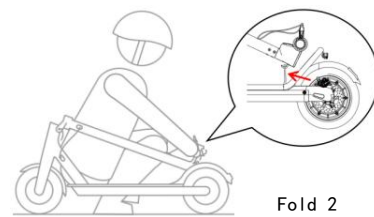
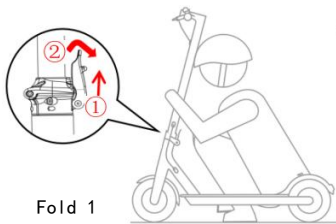

Make sure that the electric scooter is turned off. To fold, hold the handlebar stem steadily, lift the folding buckle, press the folding wrench to unlock the folding mechanism (Fold 1), and bend the forehead hook at the handlebar to hook the buckle on the rear mudguard. To open (Fold2), press the stem to remove the forehead hook from the buckle, press the buckle into the slot. Hold the stem straightly by the left hand and press the folding wrench by the right hand. Lift the folding wrench to lock the folding mechanism automatically

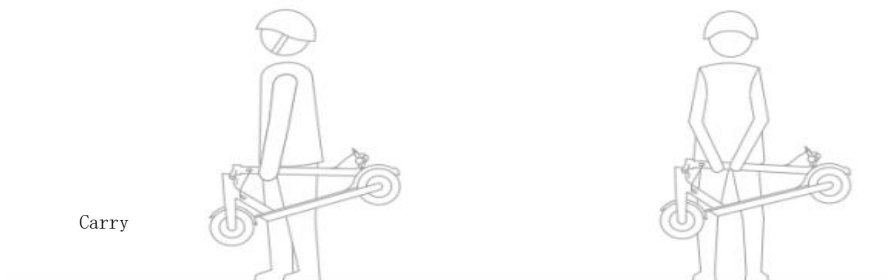

When folded, hold the handlebar stem with either one hand or both hands to carry.

9 Daily Care and Maintenance

Cleaning and Maintenance

1. If you see stains on the scooter's body, wipe with a soft damp cloth. If the stains won't scrub off, put on some toothpaste, and brush with a toothbrush, then wipe off with a damp cloth. Notes: Do not clean the scooter with alcohol, gasoline, kerosene or other corrosive and volatile chemical solvents in case of damage to the appearance and interior structure. Do not wash the scooter with a high-pressure water spray. During cleaning, make sure that the scooter is turned off, the charging cable is unplugged, and the rubber flap is closed. Water splashing in the charging cable may result in electric shock or other major problems.
2. When the scooter is not in use, keep it indoors where it is dry and cool. Do not put it outdoors for long time. Excessive sunlight, overheating and overcooling will accelerate tire aging, at the same time compromise the scooter and the battery pack's lifespan.

Battery Maintenance

1. Use original battery packs, use of other models or brands may bring about safety issues.
2. Use original charging adapter to avoid potential damage or fire.
3. Mishandling of used batteries may do tremendous harm to the environment. Please do not discard the battery at will. Follow local regulations to properly dispose used batteries.
4. After every use, fully charge the battery to prolong its lifespan.
5. Do not disassemble the battery pack, as this may result in battery damage, personal injury, or property damage.

Do not place the battery in an environment where the ambient temperature is higher than 50°C or lower than -20°C (e.g., do not leave the scooter or the battery pack in a car under direct sunlight). Do not throw the battery pack into fire as it may lead to battery failure, battery overheating, and even another fire.

To prolong the battery's lifespan, always charge before the battery running down to 0. (Battery depletion may cause permanent damage to the battery) The battery pack performs better at normal temperature, while when it is below 0°C, battery life and performance will decrease.

Typically, when it is below -20°C, the riding range is only half or less as at normal state. When the temperature rises, the riding range restores.

When scooters are not in use for a long time, it is recommended to charge the scooter battery every 0.5 to 1 month. Failure to charge in time is likely to result in damage caused by excessive 11 battery discharge, which is irreparable and is not covered by a free warranty.

If the front and rear tires of your electric scooter are not air-filled, please fill it promptly.

WARNING!

non-professionals are forbidden to dismantle the battery pack, as it may cause electric shock, short circuit, or even major safety accidents!

Shake the handlebars

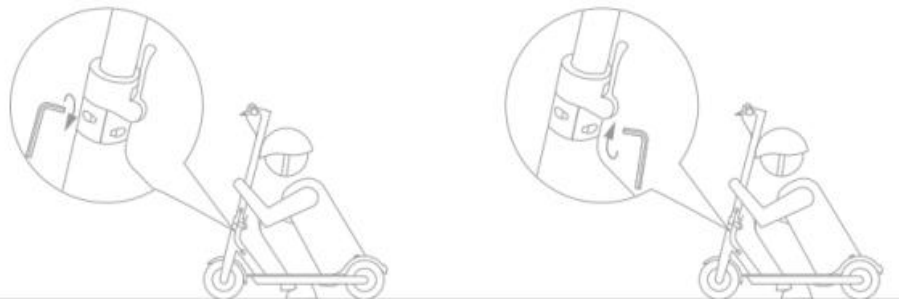





If the stem of your electric scooter is shaking, please use the wrench to lock the two screws at the folding mechanism.

10 Specifications

Operating Parameters	Name	Parameters
Dimensions	Unfold: Length*Width*Height (mm)	1160*480*1175
	Fold: Length*Width*Height (mm)	1160*480*580
Weight	Payload (kg)	30~120
	Net weight (kg)	21
Riding Requirements	Recommended Age (years)	14+
	Rider's Height (cm)	120-200
Main Parameters	Maximum speed (km/h)	20 km/h (varies according to soil and weight)
	Typical Range (km) (l)	35-40km(varies according to soil, speed and weight)
	max. Slope	10%
	Maximum climbing angle	20°
	raversable terraint	Asphalt/flat pavement: obstacles <0.4 in (1cm);gaps <1.2 in (3cm)
	Operating temperature (°C)	-10~40
	Waterproofing grade	IPX4
Battery Parameters	Rated voltage (V)	36
	Maximum input voltage (V)	42
	Rated capacity (AH)	10
Charging Adapter Parameters	Rated power (W)	84
	Rated input voltage (V)	100~240
	Rated output voltage (V)	42
	Rated current (A)	2
	Charging time (h)	About 5-6 hours
Front & Rear Tire	Tire pressure (psi)	30-35
The Motor Parameters	Rated power (W)	250

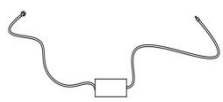
Note: (l) Typical Range:tested while riding under full power,165lbs(75kg)load,77°F (25°C),80% of max,speed on average on pavement.

11 Accessories

Item	Battery Charger	Extended Nozzle Adapter	M5 Screw	Hexagon Wrench	User Materials
Quantity	1	1	6	1	1
Graphic					<div style="border: 1px solid black; padding: 5px; text-align: center;">Scooter USER MANUAL</div>
Carefully check package contents, if anything is missing or damaged, please contact the seller.					



Made in China