

Bike Trailer

User manual

Important: Read the following instructions carefully before use and keep them for future reference.

Important: Lire les instructions suivantes attentivement avec utilisation et les conserver pour les besoins ultérieurs de référence.

INDEX

Warnings (EN)	3
Waarschuwingen (NL)	5
Warnungs (DE)	7
Avertissements (FR)	9
Maintenance (EN), Onderhoud (NL)	11
Wartung (DE)	12
Maintenance (FR)	13
Parts list	14
Assembling the base frame	15
Folding the base frame	16
Attach the rear wheels	17
Attach the front wheels	18
Attach the jogger wheel	19
Extend & secure the tow bar	20
Insert the safety flag	21
Assembling the mounting holders of drawbar	21
Assembling the reflectors	22
Using the parking brake	23
Using the safety harness	24
Back rest adjustment	25
Spring preload adjustment	26
Attaching to bicycle	26
Check before use	28

WARNINGS

- **Do read instructions before driving. Failure to comply with the instructions and warnings in this manual could result in serious injury or death.**
- The maximum total load: 44kgs
- The maximum load: 22kgs
- Max recommended trailer speed is 15km/h. Always maintain a safe speed.
- Do not use the trailer on rocky roads or other dangerous roads.
- Never leave children in or near the trailer unattended.
- Never have more than two children in the trailer at one time.
- Never use with children who cannot support their own head.
- Never use the trailer with children who cannot sit unaided.
- Bicycle riders using the trailer must be 18 years old or older and must be in good physical condition.
- Riders and children must wear approved safety helmets.
- The weight and the age of the child for which the vehicle is suitable up to 22 kg or 4 years whichever comes first.
- Assemble trailer strictly according to this instruction manual.
- Never park the trailer near a trench or dangerous road.
- Check tire air pressure before every trip.
- If necessary inflate the tires to within the range shown on the tire sidewall.
- Always use a foot or hand pump to inflate the tires.
- Overinflation of tires may result in failure and risk of serious injury.
- Do not exceed maximum pressure as shown on tires.
- Check that the bicycle is in proper technical condition.
- Always check the proper connection of the coupling.
- Always have the canopy in place.
- Take proper precautions while riding in traffic, especially when turning.
- Always check that all parts of the trailer are connected properly and tightly.
- Do not use trailer with motorized vehicles. Increased speed of motorized bicycles can damage the trailer and cause injury.
- Avoid serious injury from falling or sliding out. Always use the safety harness.
- Take extra precautions when using in the rain. Ride slowly and allow a greater margin of safety when starting, stopping, and turning.
- Do not ride on surfaces where sand, gravel, ice, oil, or slippery substances are present.
- Never tow the trailer over curbs, stairs or escalators. If you must travel through stairs, have children get out of the trailer, disconnect the trailer from the bike and take it over the stairs independently.
- Never use bike trailer without provided safety flag and reflectors.
- Do not make any modifications to the trailer which may increase the risk of failure.

- Check the trailer for damage. Do not use if damaged.
- Be sure the fasteners are tight. Tighten if necessary.
- Be sure the brakes work properly. Braking distance is increased when pulling a trailer.
- The trailer requires a wide turning radius. Do not turn sharply. Sharp changes in direction may cause a tip over.
- The assembly can only be carried out by an adult.
- Use caution when turning on loose or uneven surfaces and when going downhill.
- Allow extra clearance for the trailer when near curbs, parked cars, and other obstacles.
- Do not ride over curbs, bumps or holes.
- Do not use the trailer in hazardous weather.
- Do not pull or push the trailer with a vehicle.
- This product is not suitable for running or skating.
- Red reflectors must be visible on the rear of the trailer.
- Never ride a bicycle at night without adequate lighting. Obey all local legal requirements for lighting.
- Any load attached to the handle and/or on the back of the backrestand/or on the sides of the vehicle will affect the stability of the vehicle.
- Accessories which are not approved by the manufacturer shall not be used.

WAARSCHUWINGEN

- Lees de instructies voordat u gaat rijden. Het niet opvolgen van de instructies en waarschuwingen in deze handleiding kan ernstig letsel of de dood tot gevolg hebben.
- De maximale totale belasting: 44 kg
- De maximale belasting: 22 kg
- De aanbevolen maximumsnelheid voor aanhangers is 15 km/u. Houd altijd een veilige snelheid aan.
- Gebruik de aanhanger niet op rotsachtige of andere gevaarlijke wegen.
- Laat kinderen nooit zonder toezicht in of bij de aanhanger. Nooit meer dan twee kinderen tegelijk in de aanhanger.
- Gebruik de aanhanger nooit met kinderen die niet zelf hun hoofd kunnen ondersteunen.
- Gebruik de fietskar nooit met kinderen die niet zelfstandig kunnen zitten.
- Fietsers die de fietskar gebruiken moeten 18 jaar of ouder zijn en in goede lichamelijke conditie verkeren.
- Bestuurders en kinderen moeten goedgekeurde veiligheidshelmen dragen.
- Het gewicht en de leeftijd van het kind waarvoor het voertuig geschikt is, mag maximaal 22 kg of 4 jaar bedragen.
- Monteer de aanhanger strikt volgens deze gebruiksaanwijzing.
- Parkeer de aanhanger nooit in de buurt van een greppel of gevaarlijke weg.
- Controleer voor elke rit de bandenspanning.
- Breng de banden indien nodig op spanning binnen het bereik dat op de zijkant van de band staat aangegeven.
- Gebruik altijd een voet- of handpomp om de banden op te pompen.
- Te hoge bandenspanning kan tot defecten en ernstig letsel leiden.
- Overschrijd de maximale bandenspanning die op de banden staat aangegeven niet.
- Controleer of de fiets in goede technische staat verkeert.
- Controleer altijd of de koppeling goed is aangesloten. Zorg dat de kap altijd op zijn plaats zit.
- Neem de juiste voorzorgsmaatregelen tijdens het rijden in het verkeer, vooral bij het keren.
- Controleer altijd of alle onderdelen van de fietskar goed en stevig vastzitten.
- Gebruik de aanhanger niet samen met gemotoriseerde voertuigen. Een hogere snelheid van gemotoriseerde fietsen kan de fietskar beschadigen en letsel veroorzaken.
- Voorkom ernstig letsel door vallen of wegglijden.
- Gebruik altijd het veiligheidsharnas. Neem extra voorzorgsmaatregelen bij gebruik in de regen. Rijd langzaam en zorg voor een grotere veiligheidsmarge bij het starten, stoppen en draaien.
- Rijd niet op oppervlakken met zand, grind, ijs, olie of gladde stoffen.

- Trek de aanhanger nooit over stoepranden, trappen of roltrappen. Als je over trappen moet, laat kinderen dan uit de fietskar stappen, koppel de fietskar los van de fiets en neem de fietskar zelfstandig mee over de trap.
- Gebruik de fietskar nooit zonder de bijgeleverde veiligheidsvlag en reflectoren.
- Breng geen wijzigingen aan de fietskar aan die het risico op defecten kunnen verhogen.
- Controleer de trailer op schade. Niet gebruiken als hij beschadigd is.
- Controleer of de bevestigingsmiddelen goed vastzitten. Indien nodig vastdraaien.
- Controleer of de remmen goed werken.
- De remafstand is langer wanneer u een aanhangwagen trekt.
- De aanhanger heeft een grote draaicirkel nodig. Draai niet scherp. Scherpe richtingsveranderingen kunnen leiden tot kantelen.
- De montage mag alleen door een volwassene worden uitgevoerd. Wees voorzichtig bij het draaien op losse of oneffen ondergrond en bij het afdalen.
- Zorg voor extra ruimte voor de aanhanger in de buurt van stoepranden, geparkeerde auto's en andere obstakels.
- Rijd niet over stoepranden, hobbels of gaten.
- Gebruik de aanhanger niet bij gevaarlijk weer.
- Trek of duw de aanhangwagen niet met een voertuig.
- Dit product is niet geschikt voor hardlopen of skaten.
- Rode reflectoren moeten zichtbaar zijn op de achterkant van de fietskar.
- Fiets nooit 's nachts zonder voldoende verlichting. Volg alle plaatselijke wettelijke voorschriften voor verlichting.
- Elke lading die aan het handvat en/of aan de achterkant van de rugleuning en/of aan de zijkanten van het voertuig is bevestigd, beïnvloedt de stabiliteit van het voertuig.
- Accessoires die niet door de fabrikant zijn goedgekeurd, mogen niet worden gebruikt.

WARNUNGS

- Lesen Sie die Anweisungen vor dem Fahren. Die Nichtbeachtung der Anweisungen und Warnhinweise in dieser Anleitung kann zu schweren Verletzungen oder zum Tod führen.
- Die maximale Gesamtlast: 44kgs
- Die maximale Belastung: 22 kg
- Die empfohlene Höchstgeschwindigkeit des Anhängers beträgt 15km/h. Halten Sie immer eine sichere Geschwindigkeit ein.
- Benutzen Sie den Anhänger nicht auf steinigem oder anderen gefährlichen Straßen.
- Lassen Sie Kinder niemals unbeaufsichtigt im oder in der Nähe des Anhängers. Es dürfen sich nie mehr als zwei Kinder gleichzeitig im Anhänger befinden.
- Benutzen Sie den Anhänger nie mit Kindern, die ihren eigenen Kopf nicht stützen können.
- Benutzen Sie den Anhänger niemals mit Kindern, die nicht ohne Hilfe sitzen können.
- Fahrradfahrer, die den Anhänger benutzen, müssen mindestens 18 Jahre alt sein und über eine gute körperliche Verfassung verfügen.
- Fahrer und Kinder müssen zugelassene Schutzhelme tragen.
- Das Gewicht und das Alter des Kindes, für das das Fahrzeug geeignet ist, darf 22 kg oder 4 Jahre nicht überschreiten, je nachdem, was zuerst eintritt.
- Bauen Sie den Anhänger streng nach dieser Anleitung auf.
- Stellen Sie den Anhänger niemals in der Nähe eines Grabens oder einer gefährlichen Straße ab.
- Prüfen Sie vor jeder Fahrt den Luftdruck der Reifen.
- Falls erforderlich, pumpen Sie die Reifen bis zu dem auf der Reifenflanke angegebenen Wert auf.
- Verwenden Sie zum Aufpumpen der Reifen immer eine Fuß- oder Handpumpe.
- Ein zu hoher Reifendruck kann zu Reifenschäden führen und das Risiko schwerer Verletzungen erhöhen.
- Überschreiten Sie nicht den auf den Reifen angegebenen Maximaldruck.
- Überprüfen Sie, ob sich das Fahrrad in einem einwandfreien technischen Zustand befindet.
- Überprüfen Sie immer den korrekten Anschluss der Kupplung. Bringen Sie immer das Schutzdach an.
- Treffen Sie beim Fahren im Straßenverkehr, insbesondere beim Abbiegen, entsprechende Vorsichtsmaßnahmen.
- Prüfen Sie immer, ob alle Teile des Anhängers richtig und fest miteinander verbunden sind.
- Verwenden Sie den Anhänger nicht zusammen mit motorisierten Fahrzeugen. Erhöhte Geschwindigkeit von motorisierten Fahrrädern kann den Anhänger beschädigen und zu Verletzungen führen.
- Vermeiden Sie schwere Verletzungen durch Sturz oder Herausrutschen.

- Verwenden Sie immer den Sicherheitsgurt. Treffen Sie besondere Vorsichtsmaßnahmen, wenn Sie im Regen fahren. Fahren Sie langsam und lassen Sie beim Anfahren, Anhalten und Wenden einen größeren Sicherheitsabstand.
- Fahren Sie nicht auf Flächen, auf denen Sand, Kies, Eis, Öl oder rutschige Substanzen vorhanden sind.
- Ziehen Sie den Anhänger niemals über Bordsteine, Treppen oder Rolltreppen. Wenn Sie eine Treppe überqueren müssen, lassen Sie die Kinder aus dem Anhänger aussteigen, kuppeln Sie den Anhänger vom Fahrrad ab und bringen Sie ihn selbstständig über die Treppe.
- Benutzen Sie den Fahrradanhänger niemals ohne die mitgelieferten Sicherheitsfahnen und Reflektoren.
- Nehmen Sie keine Veränderungen am Anhänger vor, die das Ausfallrisiko erhöhen könnte
- Überprüfen Sie den Anhänger auf Schäden. Verwenden Sie ihn nicht, wenn er beschädigt ist.
- Vergewissern Sie sich, dass die Befestigungselemente fest angezogen sind. Ziehen Sie sie bei Bedarf nach.
- Vergewissern Sie sich, dass die Bremsen richtig funktionieren.
- Der Bremsweg verlängert sich beim Ziehen eines Anhängers.
- Der Anhänger erfordert einen großen Wenderadius. Wenden Sie nicht scharf. Scharfe Richtungsänderungen können ein Umkippen verursachen.
- Seien Sie vorsichtig beim Wenden auf losem oder unebenem Untergrund und beim Bergabfahren.
- Lassen Sie in der Nähe von Bordsteinen, geparkten Autos und anderen Hindernissen mehr Platz für den Anhänger.
- Fahren Sie nicht über Bordsteine, Unebenheiten oder Löcher.
- Benutzen Sie den Anhänger nicht bei schlechtem Wetter.
- Ziehen oder schieben Sie den Anhänger nicht mit einem Fahrzeug.
- Dieses Produkt ist nicht zum Laufen oder Skaten geeignet.
- An der Rückseite des Anhängers müssen rote Reflektoren sichtbar sein.
- Fahren Sie nachts nie ohne ausreichende Beleuchtung mit dem Fahrrad. Beachten Sie alle örtlichen gesetzlichen Vorschriften zur Beleuchtung.
- Jede Last, die am Griff und/oder an der Rückseite der Rückenlehne und/oder an den Seiten des Fahrzeugs angebracht ist, beeinträchtigt die Stabilität des Fahrzeugs.
- Zubehör, das nicht vom Hersteller zugelassen ist, darf nicht verwendet werden.

AVERTISSEMENTS

- Lisez les instructions avant de conduire. Le non-respect des instructions et des avertissements contenus dans ce manuel peut entraîner des blessures graves, voire mortelles.
- La charge totale maximale : 44kgs
- La charge maximale : 22 kg
- La vitesse maximale recommandée pour la remorque est de 15 km/h. Maintenez toujours une vitesse sûre.
- N'utilisez pas la remorque sur des routes rocailleuses ou d'autres routes dangereuses.
- Ne laissez jamais d'enfants sans surveillance dans la remorque ou à proximité de celle-ci. Ne jamais avoir plus de deux enfants à la fois dans la remorque.
- Ne jamais utiliser la remorque avec des enfants qui ne peuvent pas soutenir leur propre tête.
- Ne jamais utiliser la remorque avec des enfants qui ne peuvent pas s'asseoir sans aide.
- Les cyclistes qui utilisent la remorque doivent être âgés de 18 ans ou plus et être en bonne condition physique.
- Les cyclistes et les enfants doivent porter des casques de sécurité homologués.
- Le poids et l'âge de l'enfant pour lequel le véhicule est adapté ne doivent pas dépasser 22 kg ou 4 ans, selon la première éventualité.
- Assemblez la remorque en suivant scrupuleusement les instructions de ce manuel d'instructions.
- Ne jamais garer la remorque près d'une tranchée ou d'une route dangereuse.
- Vérifiez la pression d'air des pneus avant chaque voyage.
- Si nécessaire, gonflez les pneus dans la plage indiquée sur le flanc du pneu.
- Utilisez toujours une pompe à pied ou à main pour gonfler les pneus.
- Un surgonflage des pneus peut entraîner une défaillance et un risque de blessures graves.
- Ne pas dépasser la pression maximale indiquée sur les pneus.
- Vérifier que la bicyclette est en bon état technique.
- Vérifiez toujours la bonne connexion de l'attelage. Veillez à ce que la capote soit toujours en place.
- Prenez les précautions nécessaires lorsque vous roulez dans la circulation, en particulier lorsque vous tournez.
- Vérifiez toujours que toutes les parties de la remorque sont correctement et solidement attachées.
- N'utilisez pas la remorque avec des véhicules motorisés. La vitesse accrue des bicyclettes motorisées peut endommager la remorque et provoquer des blessures.
- Évitez les blessures graves en cas de chute ou de glissement.
- Utilisez toujours le harnais de sécurité. Prendre des précautions supplémentaires en cas d'utilisation sous la pluie. Roulez lentement et prévoyez une plus grande marge de sécurité lorsque vous démarrez, vous arrêtez et tournez.

- Ne roulez pas sur des surfaces où il y a du sable, du gravier, de la glace, de l'huile ou des substances glissantes.
- Ne tirez jamais la remorque sur des bordures, des escaliers ou des escaliers roulants. Si vous devez emprunter des escaliers, demandez aux enfants de descendre de la remorque, de déconnecter la remorque du vélo et de franchir les escaliers de manière autonome.
- N'utilisez jamais la remorque à vélo sans le drapeau de sécurité et les réflecteurs fournis.
- N'apportez aucune modification à la remorque qui pourrait augmenter le risque de défaillance.
- Vérifier que la remorque n'est pas endommagée. Ne l'utilisez pas si elle est endommagée.
- Assurez-vous que les fixations sont bien serrées. Serrez-les si nécessaire.
- Assurez-vous que les freins fonctionnent correctement.
- La distance de freinage est plus longue lorsqu'on tire une remorque.
- La remorque nécessite un large rayon de braquage. Ne tournez pas brusquement. Les changements brusques de direction peuvent provoquer un renversement.
- Le montage ne peut être effectué que par un adulte. Soyez prudent lorsque vous tournez sur des surfaces meubles ou irrégulières et lorsque vous descendez une pente.
- Prévoyez un espace supplémentaire pour la remorque à proximité de bordures, de voitures garées et d'autres obstacles.
- Ne pas rouler sur les bordures, les bosses ou les trous.
- N'utilisez pas la remorque par mauvais temps.
- Ne pas tirer ou pousser la remorque avec un véhicule.
- Ce produit n'est pas adapté à la course à pied ou au patinage.
- Des réflecteurs rouges doivent être visibles à l'arrière de la remorque.
- Ne jamais rouler à bicyclette la nuit sans un éclairage adéquat. Respectez toutes les dispositions légales locales en matière d'éclairage.
- Toute charge fixée à la poignée et/ou à l'arrière du dossier et/ou sur les côtés du véhicule affectera la stabilité du véhicule.
- Les accessoires qui ne sont pas approuvés par le fabricant ne doivent pas être utilisés.

MAINTENANCE

- Maintain and clean the trailer regularly to keep it in good condition for a long time.
- Check your trailer and accessories regularly for damage and signs of wear.
- Check all metal components for possible breaks or cracks. Do not use the trailer if any metal components are cracked or damaged.
- Check the trailer for bent, defective, missing or loose fasteners or catches. Tighten loose fasteners or catches and replace damaged or missing parts.
- Inspect the fabric regularly for tears, worn spots or other signs of damage.
- Clean the child carrier regularly with warm water and a mild soap solution. Never use aggressive cleaning agents or solvents.
- Clean the wheel axles and lubricate all exposed moving parts with grease or oil. Always check the wheels and carry out maintenance at least once a year.
- **Storage:**
- Store your trailer and accessories in a dry place out of direct sunlight.
- Before storage, the child carrier must be dry to prevent the formation of mould or bacteria.

ONDERHOUD

- Onderhoud en reinig de aanhangwagens regelmatig om hem lang in goede staat te houden.
- Controleer je aanhangwagens en accessoires regelmatig op schade en tekenen van slijtage.
- Controleer alle metalen onderdelen op eventuele breuken of barsten.
- Gebruik de aanhangwagens niet als er metalen onderdelen gebarsten of beschadigd zijn.
- Controleer de aanhangwagens op verbogen, defecte, ontbrekende of loszittende sluitingen. Draai losse bevestigingen of vergrendelingen aan en vervang beschadigde of ontbrekende onderdelen.
- Controleer de stof regelmatig op scheuren, versleten plekken of andere tekenen van schade.
- Reinig het kinderzitje regelmatig met warm water en een milde zeepoplossing. Gebruik nooit agressieve schoonmaakmiddelen of oplosmiddelen.
- Reinig de wielassen en smeer alle blootliggende bewegende delen met vet of olie.
- Controleer de wielen altijd en voer minstens een keer per jaar onderhoud uit.
- **Opslag:**
- Bewaar je aanhangwagens en accessoires op een droge plaats uit direct zonlicht.
- Voordat je de kinderwagen opbergt, moet hij droog zijn om de vorming van schimmel of bacteriën te voorkomen.

WARTUNG

- Pflegen und reinigen Sie den Anhänger regelmäßig, damit er lange Zeit in gutem Zustand bleibt.
- Überprüfen Sie Ihren Anhänger und das Zubehör regelmäßig auf Schäden und Verschleißerscheinungen.
- Überprüfen Sie alle Metallteile auf mögliche Brüche oder Risse.
- Benutzen Sie den Anhänger nicht, wenn Metallteile gerissen oder beschädigt sind.
- Überprüfen Sie den Anhänger auf verbogene, defekte, fehlende oder lockere Verschlüsse oder Sperren. Ziehen Sie lockere Befestigungen oder Verschlüsse nach und ersetzen Sie beschädigte oder fehlende Teile.
- Überprüfen Sie den Stoff regelmäßig auf Risse, abgenutzte Stellen oder andere Anzeichen von Beschädigungen.
- Reinigen Sie den Kindersitz regelmäßig mit warmem Wasser und einer milden Seifenlösung. Verwenden Sie niemals aggressive Reinigungsmittel oder Lösungsmittel.
- Reinigen Sie die Radachsen und schmieren Sie alle freiliegenden beweglichen Teile mit Schmierfett oder Öl.
- Überprüfen Sie die Räder immer und führen Sie mindestens einmal im Jahr eine Wartung durch.
- Lagerung:
- Lagern Sie Ihren Anhänger und das Zubehör an einem trockenen Ort und vor direkter Sonneneinstrahlung geschützt.
- Vor der Lagerung muss der Kinderanhänger trocken sein, um die Bildung von Schimmel oder Bakterien zu verhindern.

MAINTENANCE

- Entretenez et nettoyez régulièrement la remorque pour qu'elle reste longtemps en bon état.
- Vérifiez régulièrement que votre remorque et ses accessoires ne sont pas endommagés et ne présentent pas de signes d'usure.
- Vérifiez que toutes les pièces métalliques ne sont pas cassées ou fissurées.
- N'utilisez pas la remorque si des éléments métalliques sont fissurés ou endommagés.
- Vérifiez que la remorque ne présente pas de fixations ou de loquets déformés, défectueux, manquants ou desserrés. Serrez les attaches ou les loquets desserrés et remplacez les pièces endommagées ou manquantes.
- Inspectez régulièrement le tissu pour vérifier qu'il n'est pas déchiré, usé ou endommagé.
- Nettoyez régulièrement le porte-enfant avec de l'eau tiède et une solution savonneuse douce. N'utilisez jamais de produits de nettoyage agressifs ou de solvants.
- Nettoyez les axes des roues et lubrifiez toutes les pièces mobiles exposées avec de la graisse ou de l'huile.
- Vérifiez toujours les roues et effectuez un entretien au moins une fois par an.
- Stockage :
- Stockez votre remorque et ses accessoires dans un endroit sec, à l'abri de la lumière directe du soleil.
- Avant d'être stocké, le porte-enfant doit être sec pour éviter la formation de moisissures ou de bactéries.

PARTS LIST



1 X Main frame



2 X Wheels



2 X Front wheels



2 X Jogger wheel frame



1 X Jogger wheel



1 X Tow bar



2 X Blue Clamp



1 X Flag

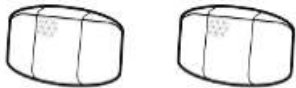

2 X Front Reflectors
(White)

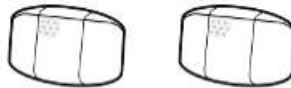

2 X Rear Reflectors
(Red)



2 X wheel Reflectors
(Yellow)



2 X Wheel Axle



2 X Screws
1 X Plastic holder

ASSEMBLING THE BASE FRAME



1. Reach into the folded bicycle trailer and pull the handlebar.
2. Pass the frame part to which the handlebar is attached under the linkage of the frame.

Note: The angle of the handlebar can be adjusted by pressing both blue buttons simultaneously.

3. Connect the frame part to which the handlebar is attached to the frame of the bicycle trailer using the black fastening hooks.
4. Secure the black fastening hooks by turning the blue locks until they engage.

5. The parts are correctly connected to each other when the connection looks like in picture 6; the textile cover is taut and nothing wobbles.
Note: Secure the textile cover by folding it over the frame and closing the Velcro fastener.

FOLDING THE BASE FRAME



1. Set the handle bar to the lowest position.

Note: The angle of the handlebar can be adjusted by pressing both blue buttons simultaneously.

2. Open the Velcro fastener that connects the textile cover to the frame.

3. To release the blue fastening hooks, press the blue fastening hooks down until they are free.

4. Push the frame part to which the handle bar is attached downwards until it is released from the anchorage. Pass this part under the frame linkage.

5. Now fold the frame together.

6. The frame is correctly folded when it looks like in picture 6.

ATTACH THE REAR WHEELS



Insert the rear wheels into the openings on the frame. When you hear a click, the rear wheels are correctly fixed and locked in place.

Note: The rear wheels can be removed by pressing the button located in the middle of the wheel.

Warning: After assembly, check the locking by pulling both wheels back and forth! The wheels must not be able to be pulled out without pressing the button. Wheels that are not fully locked can come loose when riding, which can lead to accidents with life-threatening injuries.

Note: The bicycle trailer has a wheel guard. Always fold the wheel guard outwards when using it as a bicycle trailer. The wheel guard protects the rear wheels from collision.

ATTENTION!

THE CORRECT TIRES ARE ESSENTIAL! USE ONLY THE SUPPLIED TIRES AND KEEP THEM PROPERLY MAINTAINED. INFLATE TIRES TO 30-35 P.S.I. AND CHECK PRESSURE BEFORE EACH USE. DO NOT USE HIGHER PRESSURE TIRES AS THIS WILL MAKE THE TRAILER JUMPY AND PRONE TO TIPPING OVER WHEN LIGHTLY LOADED. WE RECOMMEND ONLY TIRES WITH ROAD TREAD. DO NOT USE OFF-ROAD TIRES.

ATTACH THE FRONT WHEEL



If the bicycle trailer has the drawbar or the jogger wheel set mounted, first remove these elements and insert the blue fastening hooks back into the holes provided. Make sure that the fastening hooks are closed.

Tip: To familiarise yourself with the assembly, we recommend that you first lift the bicycle trailer at the front, tilt it backwards and support it on the handlebar. Make sure that the surface under the trailer is clean and smooth so as not to soil or damage the textile cover. Later, when you are familiar with the assembly, it is enough to lift the trailer slightly at the front for this work.

1. lift the trailer at the front or tilt it backwards.
2. insert the buggy wheel into the buggy wheel holder as far as it will go until you hear and feel it engage.
3. to remove the buggy wheel, press the blue button and pull the buggy wheel out.

Caution: Make sure that the buggy wheel is correctly engaged and cannot come loose by itself ! If the buggy wheel is not correctly engaged, the buggy wheel can come loose, which can lead to accidents and injuries.

Caution: Never ride with a mounted buggy wheel when using the trailer as a bicycle trailer! The buggy wheel could hit obstacles, which could lead to accidents and injuries.

ATTACH THE JOGGER WHEEL



1. Lift the front of the trailer or tilt it backwards. Unfasten the yellow fixing clamps on both sides and remove them.

2. Slide the front wheel arms into the mounting slots.

3. Insert the pins of the yellow mounting clamps into the holes provided.

4. Lock the mounting clamps until you hear a click.

Note: Make sure that the fixing clamps are closed. The clamp is securely closed as soon as you hear a loud click.

5. Next, insert the jogger wheel into the wheel arm slots. Ensure that the wheel lock washers are in the correct mounting holes.

TIP: If you have trouble getting the lock washers in place loosen or unscrew the nut located on the front wheel axle. (Be careful not to lose the spring located under the nut.).

6. Turn the axle nut and close the quick release.

TIP: If during use you find that the wheelchair does not keep a straight track you can correct this using the yellow knobs underneath the front wheel fork

EXTEND & SECURE THE TOW BAR

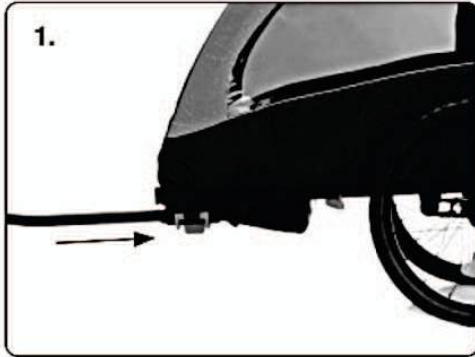

1. Insert the drawbar into the opening on the left side of frame. The opening is located under the front reflector.

2. Secure the drawbar with the blue clamp. To do this, insert steel bolt of the clamp into the hole on the side of the bicycle trailer and close the clamp. The clamp is securely closed as soon as you hear a loud clack.

Note: Opening and closing the clamp is not smooth and requires a certain amount of force. This is necessary to guarantee a secure hold of the clamp.

ATTENTION !

1. Steel bolt must always be locked with the clamp when the trailer is used.

2. Always make sure that the drawbar is securely mounted. Failure to do so may result in serious accidents and injuries.

INSERT THE SAFETY FLAG



Insert the flag pole into the sleeve located at the left rear corner of the trailer.
WARNING: The safety flag is an important safety feature that warns others a trailer is present and on the bicycle. Always have the safety flag on the trailer when in use !

ASSEMBLING MOUNTING HOLDER OF DRAWBAR



1. Clipping the plastic holder onto the tube, make sure the screw holes are in the same position.
2. Using screws to fix the plastic holder.
3. Insert the drawbar and hook the elastic on the side of fabric.

ASSEMBLING THE REFLECTORS

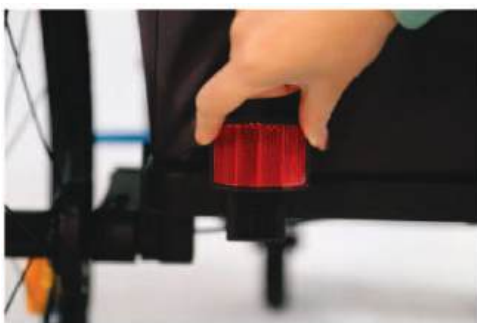

1. Insert two white reflectors into the holder on the front.
2. Insert two red reflectors into the holder on the back.
3. Insert two yellow reflector into the wheel.

USING THE PARKING BRAKE

The parking brake prevents the bicycle trailer from unintentionally rolling away when stationary. It is not suitable for braking a rolling bicycle trailer. Always apply the parking brake when you:

- 1.) Park buggy.
- 2.) Allow your child to get in and out of the trailer when using it as buggy or bicycle trailer.
- 3.) Lock the trailer so that it does not roll away.



The parking brake can be released by lifting the foot on the foot brake.



The parking brake can be fixed by placing the foot on the foot brake.

WARNING!

Always apply the parking brake after parking the trailer and when getting in and out of the trailer with the children. Check that the trailer cannot roll away by pulling it slightly forwards and backwards. An unsecured trailer could cause accidents with life-threatening injuries by rolling away or could roll away when getting in or out of the trailer, causing serious injuries to the children.

- Always engage parking brake at each stopover.
- If the rod can't be slid into socket easily, try to move the trailer forward slowly until brake is working.
- Never drive with the parking brake applied! This can damage the brake mechanism.

USING THE SAFETY HARNESS

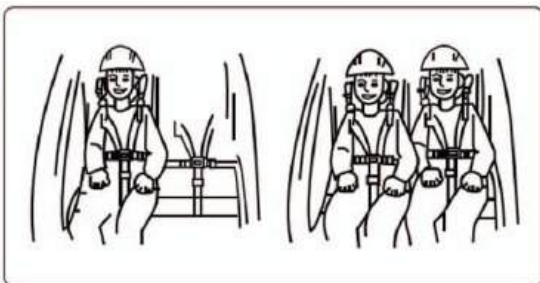

The 5-point safety harness system consists of two shoulder straps, two lap straps and a crotch strap secured in a buckle. Padded shoulder straps provide more comfort.

1. Open the straps by first pressing the red buttons and at the same time the black buttons on the buckle. The individual straps should now come out of the buckle.
 2. Let the crotch strap hang down towards the footwell and place the two shoulder straps and the lap straps to the sides of the seat for the time being, so that you can comfortably put your child into the seat.
 3. Place the child in the seat with the harness open.
 4. Guide the crotch strap with the buckle between the child's legs upwards to the upper body.
 5. Guide the hands away from the child.
 6. Pass the child's hands between the shoulder straps and lap straps. Place the shoulder straps over the child's shoulders. Now insert the ends of the straps into the buckle.
- Tip:** The seat belts can be adjusted to the child's height.
7. Adjust the seat belts so that the child is held securely by the belts, but not so tight that the seat belts cut in.

Tip: If a flat hand can be slid between the straps and the baby's body, the straps are usually adjusted correctly.

Warnings:

- The distance between the shoulder and lap belts and the child's body should be as small as possible so that the child is held optimally in the seat. If the distance is too great, the child cannot be restrained sufficiently in the seat, which can lead to life-threatening injuries in the event of an accident. If the distance is too small, the seat belts may possibly cut into the child's body.
- Always fasten the child's seat belt! Your child could otherwise suffer life-threatening injuries in dangerous situations.
- Seat belts that are adjusted too loosely or buckles that are not properly fastened can cause life-threatening injuries to your child in the event of an accident.
- Avoid serious injury from falling or sliding out. Always properly secure the passengers with the safety harness.

- It may be dangerous to leave your child unattended. Never leave your child unattended in or near the bicycle trailer.
- Never transport babies under 6 months or children who cannot yet sit independently.

BACK REST ADJUSTMENT

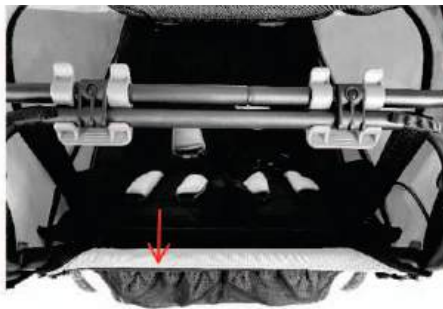

Move the back rest backward by pressing both buckles and releasing the belt.

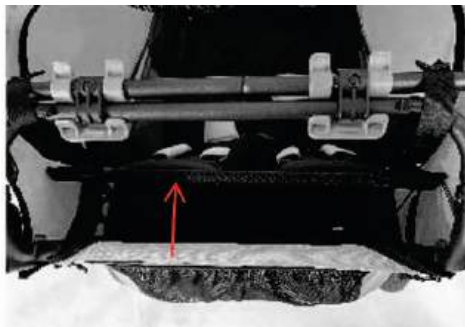

Move the back rest forward by pulling tightly the end of belt.

ATTACHING TO BICYCLE

Check whether the towing bike is approved by the manufacturer for towing trailers! Pulling trailers with an unsuitable towing bike can lead to frame fractures and accidents with life-threatening injuries.

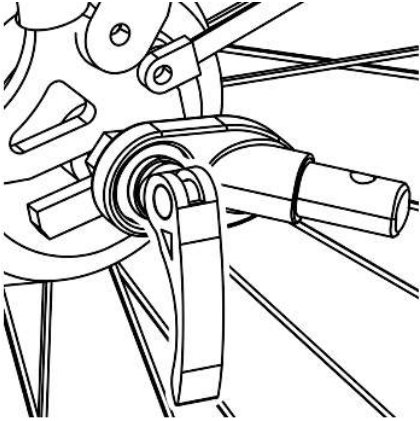

1. Quick-release Axle:

Remove the quick-release from the left side of bike's rear axle. Install the hitch between the quick-release and frame. Tighten the quick-release following the bike manufacturer's manual. Hitch can remain on the bike when the trailer is removed.

WARNING: The tension-adjusting nut must engage the threads for at least five full turns in order to ensure adequate clamping force for holding the rear wheel securely. Failure to tighten the tension-adjusting nut fully may result in accidents with serious injury or death. If the quick-release skewer is too short, it must be replaced. Consult a professional bicycle mechanic for the appropriate parts and assistance.

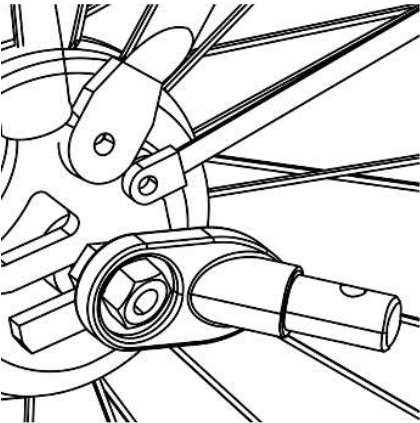

2. Nutted Axle:

Unscrew the nut with washer from the left side of bike's rear axle. Install the hitch onto the axle and screw the nut back on with the washer.

WARNING: The axle nut must engage the threads for at least five full turns in order to ensure adequate clamping force for holding the rear wheel securely. Failure to tighten the nut fully may result in accidents with serious injury or death. If the axle is too short, the Universal Hitch cannot be used! Consult a professional bicycle mechanic for the appropriate parts and assistance.

3. Thru Axle: The universal hitch doesn't fit a bike with thru axle. Please consult the retailer for possible solution.

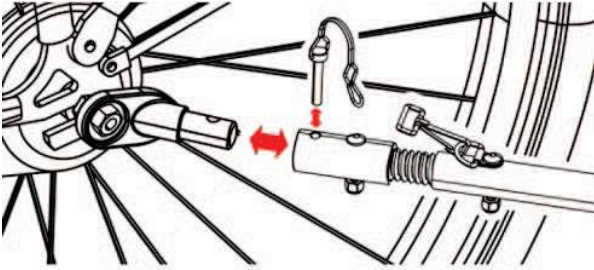

Connect the coupler on the tow bar and secure the safety pin.

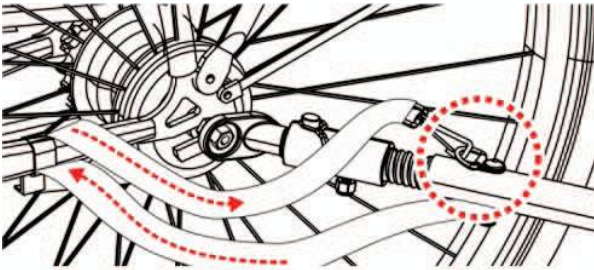

Once the tow bar is attached, wrap safety belt around the frame of the bike and hook onto the D-ring on the tow bar.

CHECK BEFORE USE

1. Wheels are properly secured to the trailer.
2. Tires are inflated to recommended pressure on the tire side wall.
3. Tow bar is properly secured to the trailer.
4. Hitch is properly secured to the bicycle.
5. All safety pins are securely locked in place.
6. Safety strap on the tow bar is properly installed.
7. Make sure that bicycle is in proper working order, especially brakes and tires (refer to bicycle manufacturer's instructions).
8. Safety flag is in place.